



PLYGRID™ Cross-Laminated Corrugated Panel

January 2003

Description

PLYGRID cross-laminated corrugated panels offer solutions to a wide variety of challenging design problems. Produced from layers of cross-laminated aluminum foil corrugations with a flat sheet of aluminum foil on each face, PLYGRID can be cut or machined to form ribs for various aircraft wing or control surfaces. It is also ideal for such diverse applications as heat exchangers, flow diffusers and to prevent liquid from sloshing inside tanks.

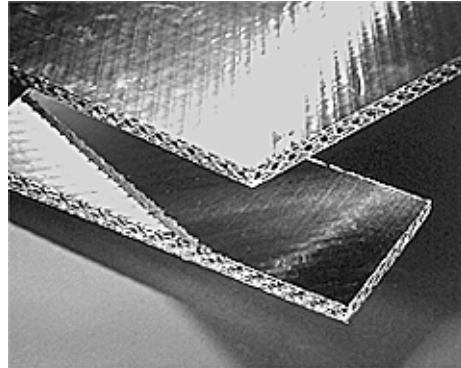

PLYGRID is constructed as shown on the reverse.

This exploded view of a typical piece shows that the corrugations are laid up in pairs, and that the corrugation angle A-B is 45 degrees from the edges of the panel. This unique structure offers considerable structural strength in both the length and width directions in a very lightweight panel.

From model making and fuel tanks to vacuum tables and control surface ribs, PLYGRID is the one solution to your most challenging structural core problems.

Applications

- Liquid motion dampening
- Model making
- Fuel tanks
- Heat exchangers
- Vacuum tables
- Aircraft control surfaces
- Flow diffusers

Features

- Excellent dimensional stability in three dimensions
- High crush efficiency (50-70%)
- Easily machined without cell reinforcement
- Fully vented, allowing volatiles/pressure to escape
- Stable during shipping and handling
- Bonded equally well with all types of adhesives
- Flat metal surface on exterior

Availability

- Flat sheets
- Fabricated shapes

PLYGRID cross-laminated corrugated panel is produced in 5052 alloy, with either our DURA-CORE™ II modified conversion coating or our PAA-CORE™ phosphoric acid anodized protection. Custom dimensions, cell sizes, alloys, tolerances and mechanical properties are available.



How to Order

When ordering, please specify PLYGRID using the following format:

Example: Ply - PAA - 0.73 - 1/8, where

Product	Coating	Density	Cell Size
PLY	DUR or PAA	0.73	1/8

Available Dimensions

	Standard		Maximum		Tolerance	
	inches	mm	inches	mm	inches	mm
Ribbon (L)	96	2438	96	2438	+1.0 / -0.0	+25.4 / -0.0
Transverse (W)	12	305	12	305	±0.250	±6.350
Thickness (T)	1	25	1	25	±0.120	±3.048
Weight	see mechanical characteristics chart				±10%	
Cell Size	see mechanical characteristics chart				±10%	

Plygrid Mechanical Characteristics (Typical values at 75° F/23° C)							
Density	Cell Size	Bare Compressive Strength		Shear Strength			
				L		W	
lbs/ft ³	inches	psi	MPa	psi	MPa	psi	MPa
6.1	1/8	500	3.45	400	2.76	240	1.65
8.1	1/8	780	5.38	570	3.93	380	2.62
4.4	3/16	275	1.90	235	1.62	155	1.07
5.7	3/16	435	3.00	325	2.24	215	1.48
8.1	3/16	870	6.00	515	3.55	340	2.34
3.4	1/4	190	1.31	165	1.14	100	0.69
4.3	1/4	275	1.90	225	1.55	145	1.00
6.0	1/4	550	3.79	375	2.59	245	1.69
7.9	1/4	750	5.17	500	3.45	315	2.17
2.3	3/8	100	0.69	100	0.69	60	0.41
3.0	3/8	160	1.10	145	1.00	90	0.62
4.2	3/8	280	1.93	220	1.52	145	1.00
5.4	3/8	400	2.76	305	2.10	200	1.38

PLYGRID® DETAILS

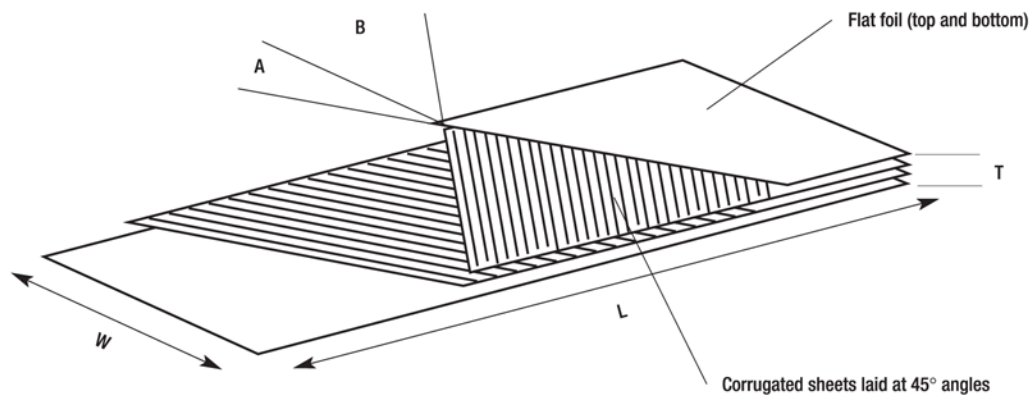

CELL SIZE MEASUREMENT

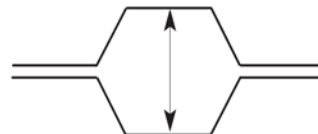

Alcore gives no warranties, expressed, implied or statutory, or otherwise, as to the description, quality, fitness, capacity, or any other matter, of the properties described. The data given represents typical values to be expected. Through additional testing of each lot it is possible to verify that the product exceeds the tabulated values. It is recommended, however, that prospective users evaluate the materials to determine their suitability for the users' specific requirements. Values are given on the condition that the user assumes all risk and that responsibility for any loss or damage caused by or resulting from the use of such information is disclaimed by Alcore.

Alcore
Lakeside Business Park
1502 Quarry Drive
Edgewood, MD 21040 USA
Tel: +1 (410) 676-7100
Fax: +1 (410) 676-7200
Email: sales@alcore.com
www.alcore.com
www.mcgillcorp.com

Alcore Brigantine
Route de l'Aviation
64600 Anglet France
Tel: +33 (0)5 59 41 25 25
Fax: +33 (0)5 59 41 25 00
Email: sales@alcorebrigantine.fr
www.mcgillcorp.com/alcore_brigantine